

HXS SERIES

清双色注塑机

CLEAR TWO-COLOR INJECTION MOLDING MACHINE



- 具有主、副两个注射部件,由专业电脑程序控制两根螺杆同时或交替注射,以达到制品色彩美丽如云的特殊效果。
With major and minor two injection components, can inject synchronously or alternately through the professional computer controlling two screw bars. So as to get the plastic products with beautiful color;
- 也可以生产夹心制品,降低成本。
Also can manufacture the sandwich plastic products, and the cost is reduced;
- 本机可广泛用于PP、PE、PS等原料的双色成型。
Can be widely used for PP, PE, PS and other raw materials in two color forming.



**Series of products
Making The First-class Products!**

倾心打造, 出一流精品!

| 参数 | PARAMETER | UNIT | HXS160 | | | | | HXS200 | | | | HXS280 | | | | | | HXS400 | | | | | |
|--------|-----------------------------------|-----------------|--------------------|-----|------|-----|------|--------------------|-----|------|------|--------------------|-----|-----|-----|-----|-----|--------------------|------|------|-------|-----|-----|
| 注射装置 | INJECTION UNIT | | A组/B组 | | | | | A组/B组 | | | | A组A | A组B | A组C | B组A | B组B | B组C | A组A | A组B | A组C | B组A | B组B | B组C |
| 螺杆直径 | Screw diameter | mm | 22 | 25 | 28 | 32 | 36 | 28 | 32 | 36 | 40 | 38 | 42 | 45 | 32 | 35 | 38 | 45 | 50 | 55 | 38 | 42 | 45 |
| 螺杆长径比 | Screw L/D ratio | L/D | 22 | 22 | 22 | 23 | 21 | 22 | 23 | 21 | 21 | 23 | 21 | 20 | 23 | 22 | 20 | 22 | 20 | 19 | 23 | 21 | 20 |
| 理论注射容积 | Injection capacity in theory | cm ³ | 49 | 63 | 80 | 132 | 167 | 80 | 132 | 167 | 207 | 210 | 256 | 294 | 133 | 164 | 187 | 342 | 422 | 510 | 210 | 256 | 294 |
| 注射重量 | Injection weight(ps) | g | 44 | 58 | 72 | 120 | 152 | 72 | 120 | 152 | 188 | 190 | 233 | 268 | 120 | 150 | 170 | 311 | 384 | 465 | 190 | 233 | 268 |
| | | oz | 1.5 | 2.0 | 2.5 | 4.2 | 5.3 | 2.5 | 4.2 | 5.3 | 6.6 | 6.7 | 8.2 | 9.4 | 4.2 | 5.2 | 5.9 | 10.9 | 13.5 | 16.4 | 6.7 | 8.2 | 9.4 |
| 注射压力 | Injection pressure | MPa | 382 | 296 | 236 | 297 | 234 | 236 | 297 | 234 | 190 | 262 | 215 | 187 | 297 | 248 | 210 | 236 | 191 | 158 | 262 | 215 | 187 |
| 注射速率 | Injection rate | g/s | 63 | 82 | 103 | 82 | 103 | 105 | 83 | 106 | 131 | 103 | 126 | 144 | 58 | 70 | 82 | 150 | 185 | 225 | 97 | 118 | 135 |
| 塑化能力 | Plasticizing capacity | g/s | 4 | 6 | 9 | 11 | 13.6 | 9 | 11 | 13.9 | 18.4 | 17 | 21 | 23 | 10 | 12 | 15 | 21 | 26 | 33 | 17 | 21 | 23 |
| 螺杆转速 | Screw speed | rpm | 300 | | | | | 300 | | | | 240 | | | 220 | | | 190 | | | 240 | | |
| 合模装置 | CLAMPING UNIT | | | | | | | | | | | | | | | | | | | | | | |
| 合模力 | Clamping force | kN | 1600 | | | | | 2000 | | | | 2800 | | | | | | 4000 | | | | | |
| 移动模板行程 | Moving mould-plate stroke | mm | 400 | | | | | 500 | | | | 500 | | | | | | 620 | | | | | |
| 最大模厚 | Max.Mould height | mm | 550 | | | | | 570 | | | | 510 | | | | | | 650 | | | | | |
| 最小模厚 | Min.Mould height | mm | 230 | | | | | 250 | | | | 180 | | | | | | 250 | | | | | |
| 拉杆有效间距 | Space between tie-bars | mm | 720 x 420 | | | | | 840 x 520 | | | | 920 x 580 | | | | | | 1020 x 620 | | | | | |
| 液压顶出力 | Hydraulic ejector force | kN | 33 | | | | | 33 | | | | 40 | | | | | | 65 | | | | | |
| 液压顶出行程 | Hydraulic ejector stroke | mm | 100 | | | | | 110 | | | | 150 | | | | | | 200 | | | | | |
| 顶出点数 | Ejector number | n | 3x2 | | | | | 3x2 | | | | 3x2 | | | | | | 3x2 | | | | | |
| 转盘直径 | Wheel diameter | mm | 750 | | | | | 900 | | | | 1000 | | | | | | 1100 | | | | | |
| 其它 | OTHER | | | | | | | | | | | | | | | | | | | | | | |
| 油泵压力 | Pump pressure | MPa | 17.5 | | | | | 17.5 | | | | 17.5 | | | | | | 17.5 | | | | | |
| 电机功率 | Motor power | kW | 16+16 | | | | | 16+16 | | | | 21 | | 16 | | | | 30 | | | 21 | | |
| 加热功率 | Heating capacity | kW | 7 | | 10.5 | | | 7 | | 10.5 | | 10.95 | | 9.1 | | | | 13.35 | | | 10.95 | | |
| 外形尺寸 | Machine dimension | m | 5.23 x 1.65 x 2.07 | | | | | 5.50 x 1.83 x 2.10 | | | | 6.17 x 1.98 x 2.10 | | | | | | 7.30 x 2.24 x 2.50 | | | | | |
| 机器重量 | Machine wight | t | 8.5 | | | | | 9.5 | | | | 10 | | | | | | 17 | | | | | |
| 油箱容积 | Oil tank capacity | L | 380 | | | | | 410 | | | | 510 | | | | | | 820 | | | | | |
| 转盘承重 | Bearing capacity of rotary platen | t | 0.8 | | | | | 1.2 | | | | 1.6 | | | | | | 2.5 | | | | | |

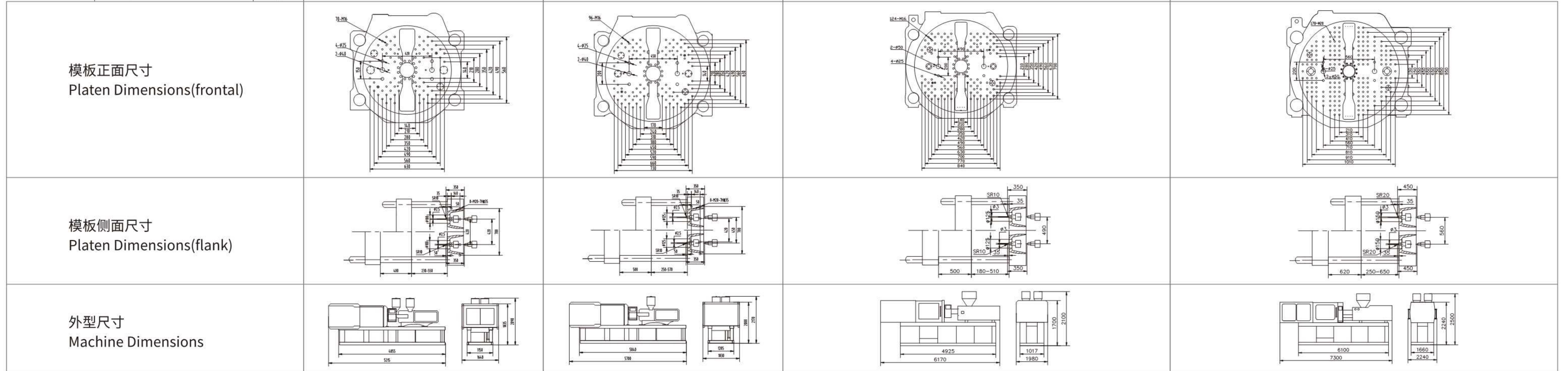

产品技术参数更改, 恕不另行通知 Due to continual improvement, specifications are subject to change without notification

例: Example: HX(*)98/370

